

PERFORMANCE

Model	Maximum flow rate			Maximum head	
	l/min	cu.m/hr	gall/min	metres	feet
TS65B15	667	40	146	35	115

Maximum power absorbed 6.5kW at 1500rpm

DIMENSIONS IN MM (APPROX.)

WEIGHT: 45kg

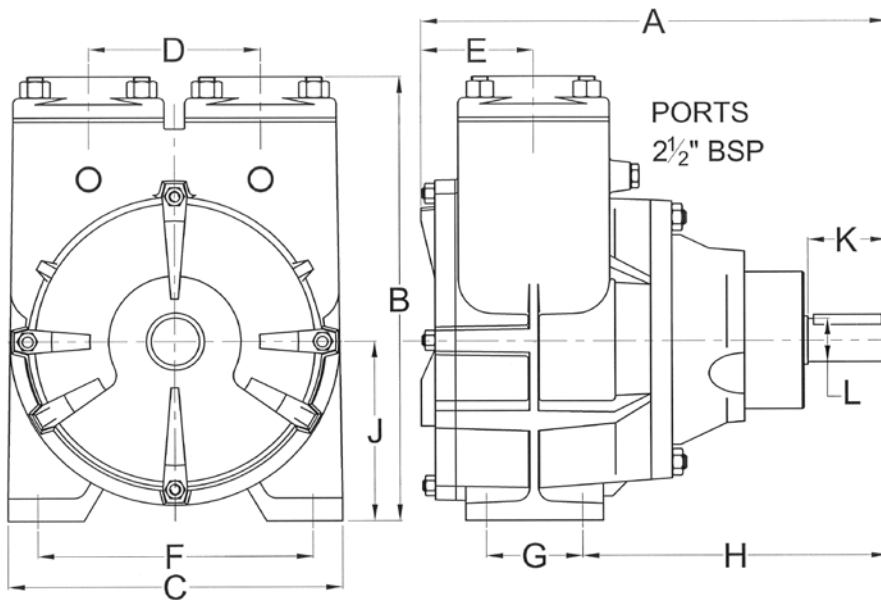

A	B	C	D	E	F	G	H	J	K	L
339	325	243	125	82	200	70	222	132	58	Ø32

MATERIALS OF CONSTRUCTION

Pump casing	bronze
Impeller	bronze
Port counterflanges	bronze
Shaft	stainless steel AISI316
Bearing housing	cast iron
Pump head bolts	stainless steel
O-ring static seal	nitrile rubber

Pump performance and specification are subject to alteration without notice

AVAILABLE CLUTCHES (ask for a data sheet)

Clutch Type	Pulley Pitch Dia	Pulley Belt Section	No of Belts	FP Code
MANUAL	170mm	SPB	3	FP-94-8020811
24v dc	180mm	SPB	2	FP-94-8010527

FP PUMPS

TS65B15

2½" BRONZE SELF-PRIMING SIDE CHANNEL PUMP

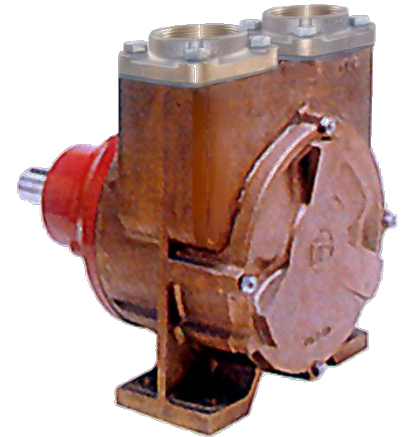

- ◆ reliable continuous duty pump
- ◆ corrosion-resistant bronze, with stainless steel shaft
- ◆ self-priming up to 5m
- ◆ flow can be reversed by a simple modification
- ◆ carbon-ceramic mechanical shaft seal

BRONZE PUMPS for SEAWATER

Xylem Water Solutions UK Ltd
 Bingley Road
 Hoddesdon
 Hertfordshire • EN11 0BU • UK

Tel: +44 (0)1462 480380
 Fax: +44 (0)1462 482422
 mail@cleghorn.co.uk
 www.jabscoshop.com

